

# Explosionproof Floodlight, 1x150W to 1x600W HPS/MH

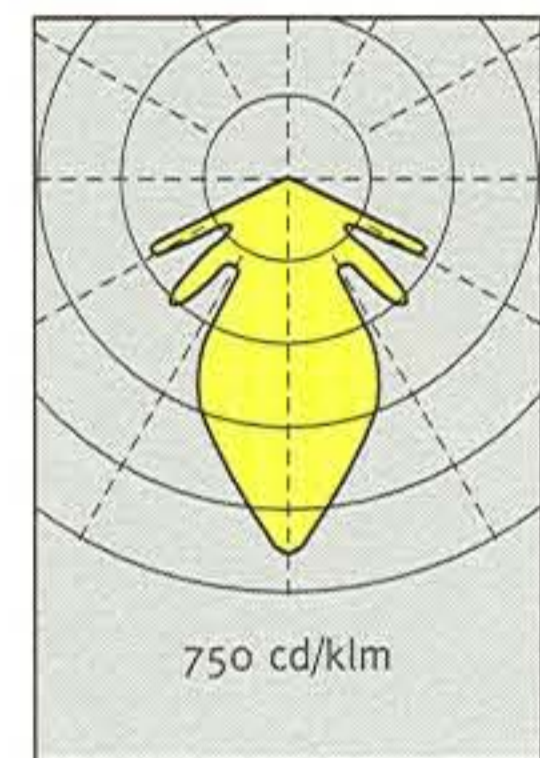

1

IP67



## Application

Hazardous areas zone 1 and 2

## Protection type

EEx de IIB T<sub>3</sub>/ T<sub>2</sub>

## Protection class

IP 67

## Insulation class

1

## Ambient temp.

-20°C to +55°C

## Housing

copper-free aluminium with yellow polyester paint finish.

## Diffuser

borosilicate glass

## Reflector

aluminium anodized

## Lamp base

E 40

**Lamps** (not included)  
high pressure sodium lamp (HPS), metal halide lamp (MH)

## Electric

230V, 50Hz or 60Hz  
flexible wiring, high temperature resistant

## Cable entry

plastic cable gland  
2 M25x1.5 and 1 M25  
blind plug

## Mounting

adjustable mounting bracket, 2 x Ø 14 mm,  
1 x Ø 26 mm

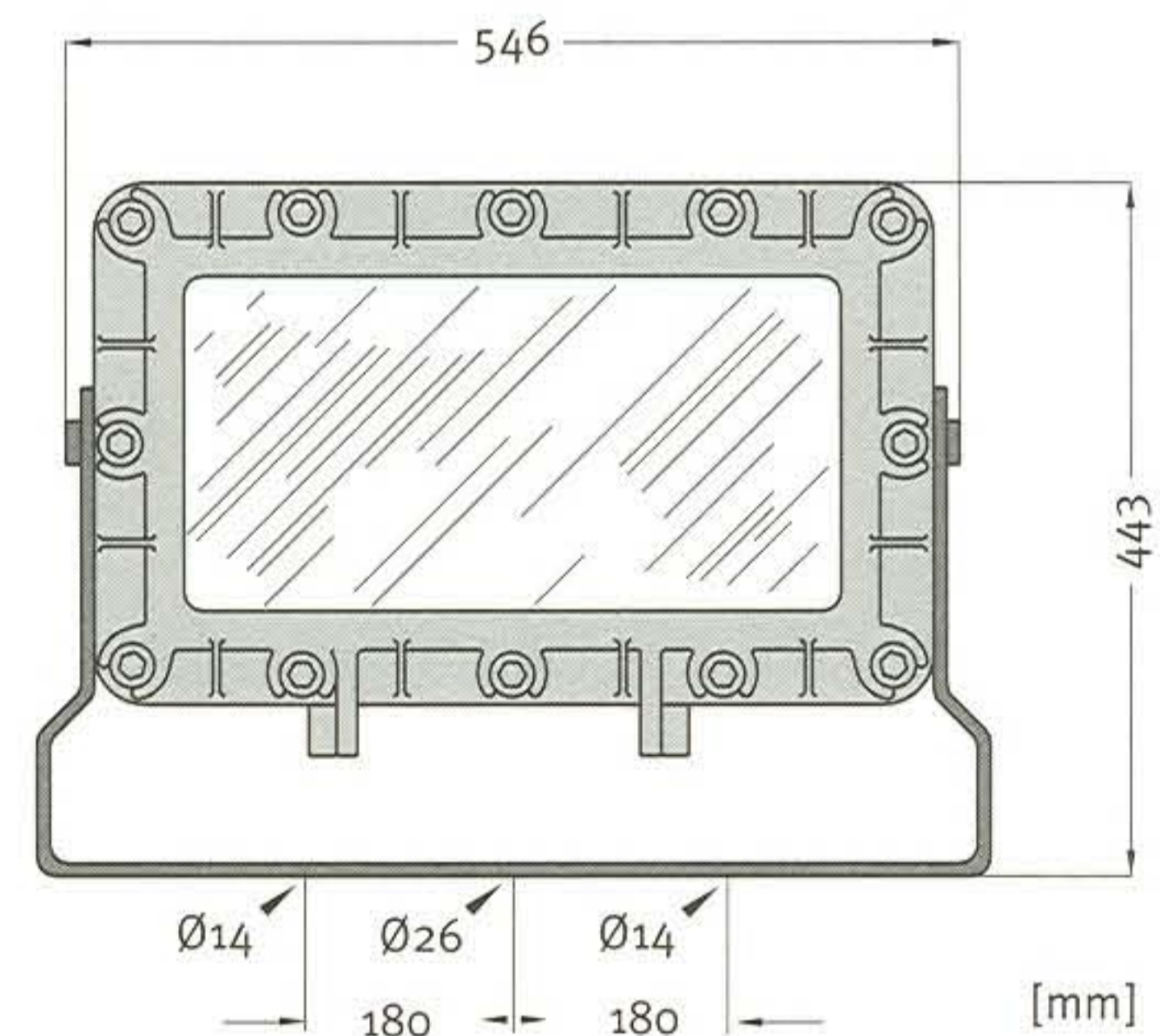

Type	Code	Lamps	Temp.-Class.	Weight kg
ST 23 150 ..	PX 15	HPS/MH 150W	T <sub>3</sub>	31
ST 23 250 ..	PX 25	HPS/MH 250W	T <sub>3</sub>	31
ST 23 400 ..	PX 40	HPS/MH 400W	T <sub>3</sub>	31
ST 23 600 ..	PX 60	HPS 600W	T <sub>2</sub>	31

